

PREMIUM SERIES

Mains pressure indoor electric hot water systems
European quality, innovation and efficiency.

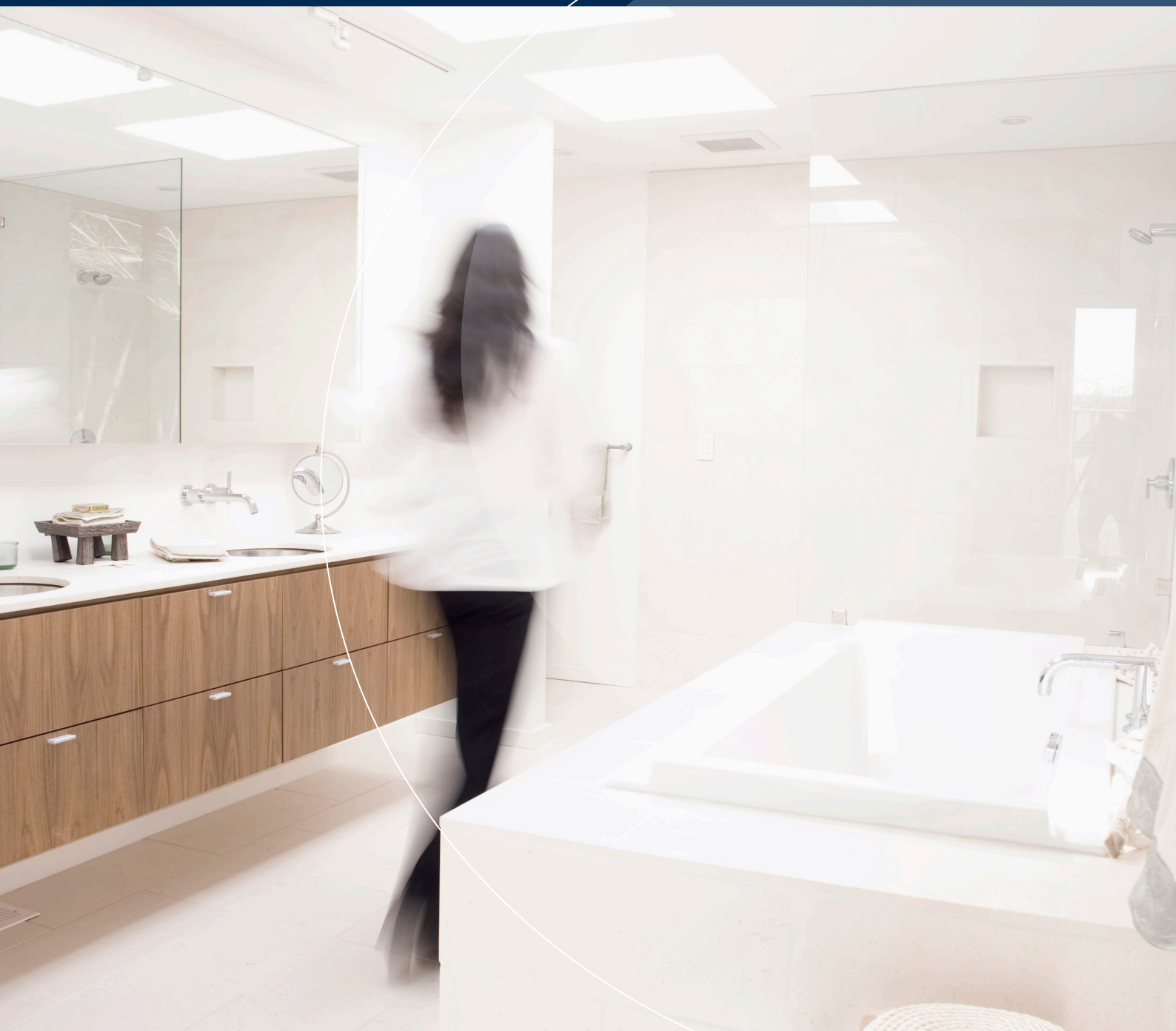

Why choose Atlantic?

Established in 1931, Atlantic is now a world leading manufacturer of electric hot water systems in Europe.

Today, Atlantic has 19 manufacturing plants across Europe producing some 3 million units per year. Atlantic hot water systems are manufactured to exacting standards incorporating high quality materials and advanced control systems to increase the performance and life of the tanks.



Performance & Reliability

Atlantic products are sold in over 50 countries earning a reputation for quality, reliability and efficiency in demanding environments. Atlantic is an international brand preferred by discerning plumbing professionals and customers across the globe.

ISO 9001 Certified

The ISO 9001 Certificate has been attributed to Atlantic manufacturing plant

Indoor System

The Atlantic Premium range is designed for indoor installation.

O'PRO Protection / Ohmic Resistance

Adds 50% tank life

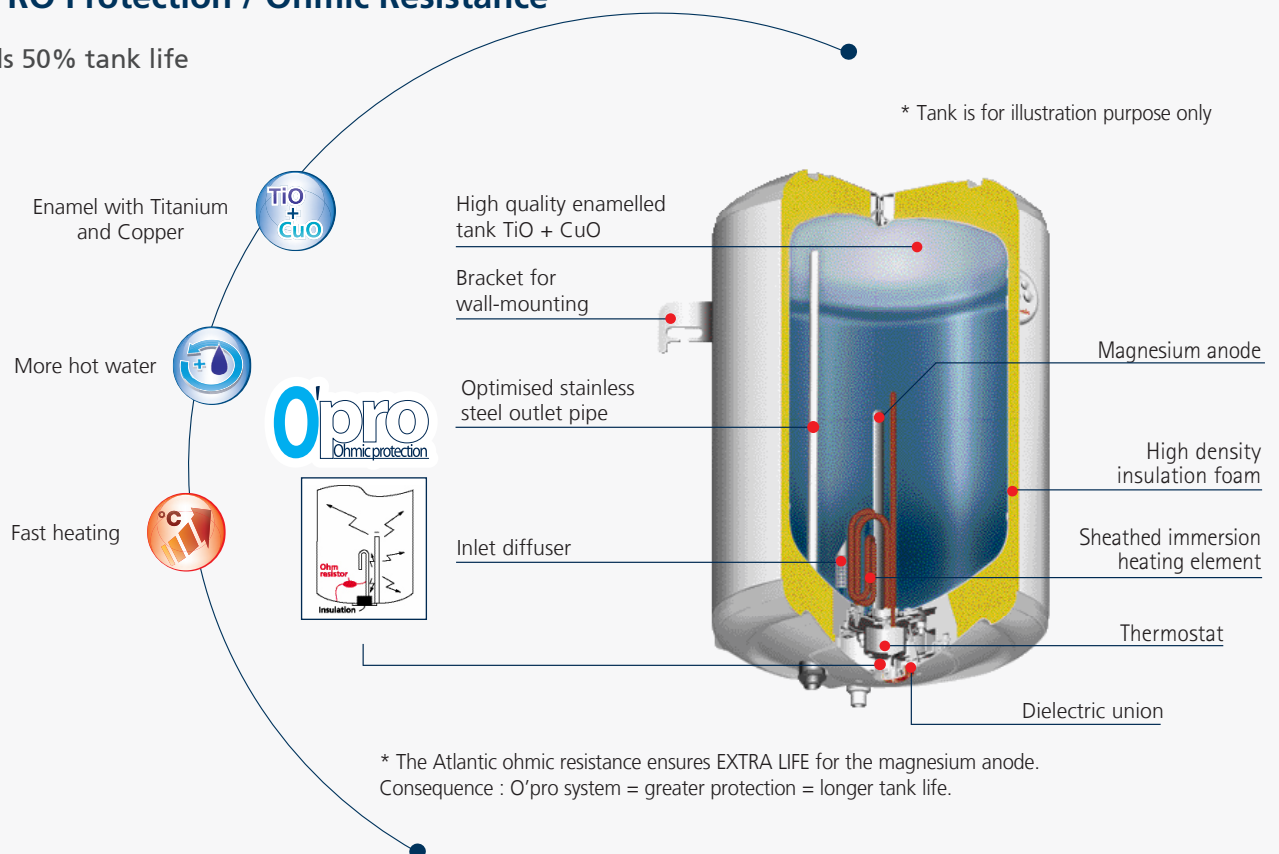



High Efficiency & Energy Saving

- Exceeds New Zealand "MEPS" energy efficiency performance standard.
- High efficiency cold water inlet.
- CFC – free high density insulation for more energy savings.

Quality - Durability - Reliability

- O'Pro ohmic Protection Technology – A patented passive electronic anti-corrosion system, guarantee to extend the lifespan of the tank.
- New generation tank lining – ZIRCON - Copper & Titanium Vitreous enamelling.
- Magnesium anode for increased protection of the tank.
- Easy access to inner tank at the front to replace anode or de scale tank.
- IP 24 Compliant.
- Meets AS/NZS60335.2.21 for Electrical Safety
- Mechanical adjustable thermostat with integrated thermal cut out.
- Specific lip gasket to avoid rust around the element flange.

Warranty, terms and conditions

Warranty 10 years on cylinder, 3 years labour on the cylinder, 1 year parts and labour warranty on all components for domestic installations. Conditions apply. See installation manual



Designed & Manufactured in France

PREMIUM SERIES

Versatility of a wide range of water heaters with O'Pro protection technology for +50% tank life time

Installation dimensions (in mm)

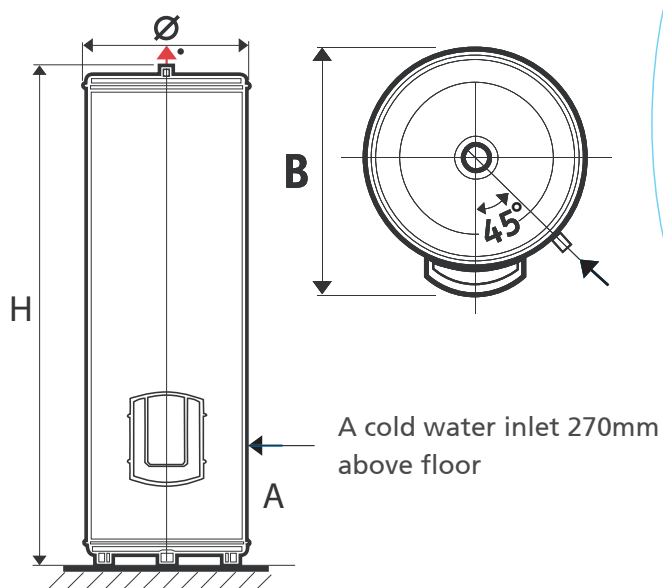

Premium Dimensions

Model	Capacity	Rating (W)	Dimensions (mm)				Net weight (kg)
			ø	H	A	B	
272014	150 L	2200	575	1015	270	590	41
282029	200 L	2200		1275			51
282035	250 L	3000		1500			63
292039	300 L	3000		1780			73

Premium Specifications

Model	Capacity	Relief Value	Pressure Limiting Valve	Hot Water Recovery at 60°C (t - 50°C)	Water Connections
272014	150 L	850 kPa	500 kPa	46 lt/hr	¾ / 20 mm
282029	200 L	850 kPa	500 kPa	45 lt/hr	¾ / 20 mm
282035	250 L	850 kPa	500 kPa	57 lt/hr	¾ / 20 mm
292039	300 L	850 kPa	500 kPa	56 lt/hr	¾ / 20 mm

Atlantic Australasia - New Zealand
 T 0800 422 000
 E info@atlantic.nz
 W www.atlantic.nz



A trusted New Zealand brand for over 10 years